

DEUBLIN

HPS Series for High Pressure Steam Service in Corrugators

- monoflow and duoflow design
- self-supported rotating union
- seals and bearings made of special Carbon Graphite
- convex seal ring better suited to handle mechanical and thermal shock
- external mechanism to adjust siphon pipe through end cap
- nickel-plated front and rear end cap
- nickel-plated ductile iron housing
- stainless steel spring
- heavy duty steel rotor design
- dual bearings for extended service life

Operating Data

Maximum Saturated Steam Pressure	250 PSI	17 bar
Maximum Speed	400 RPM	400/min
Maximum Temperature	400°F	200°C

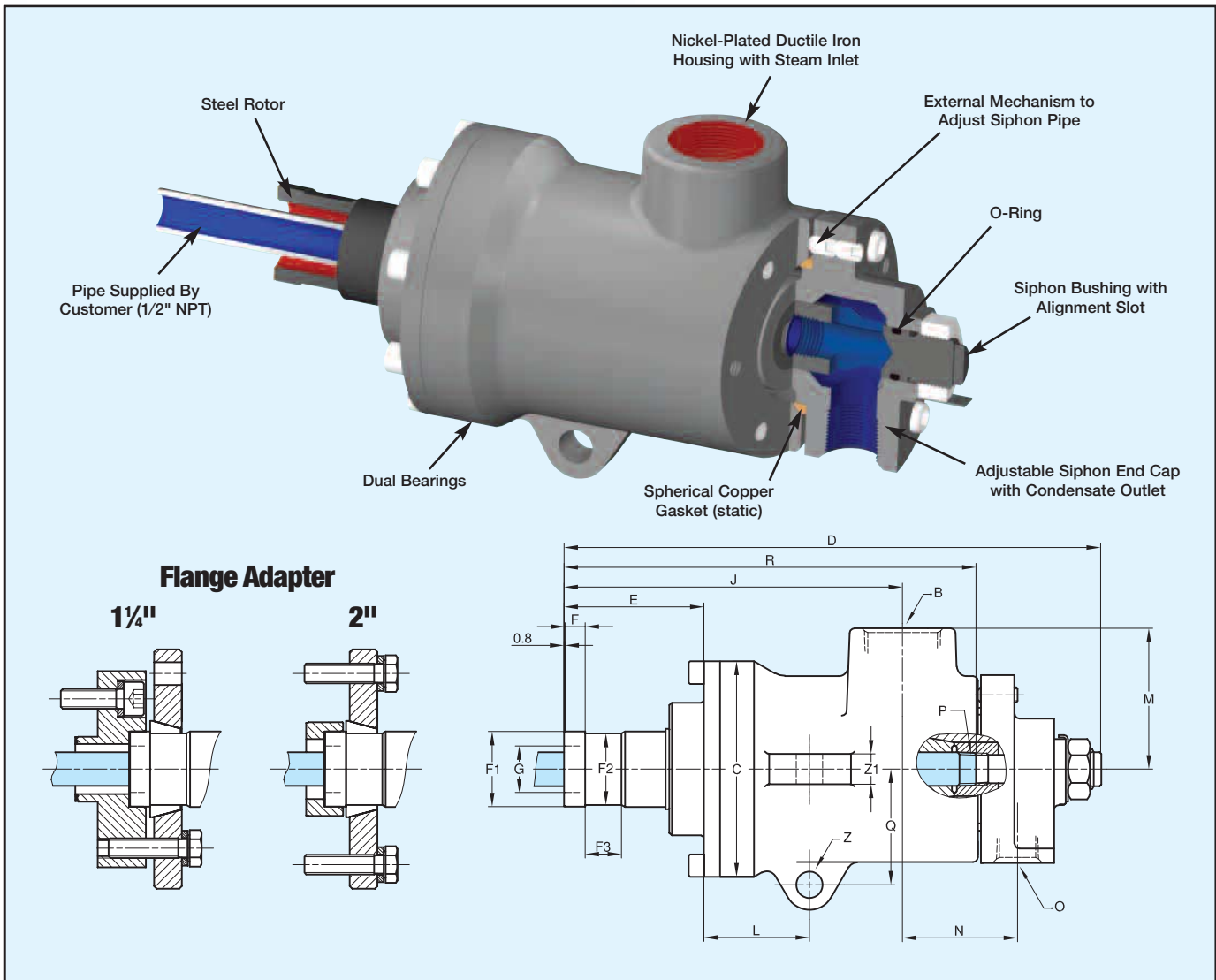

Flange Adapter

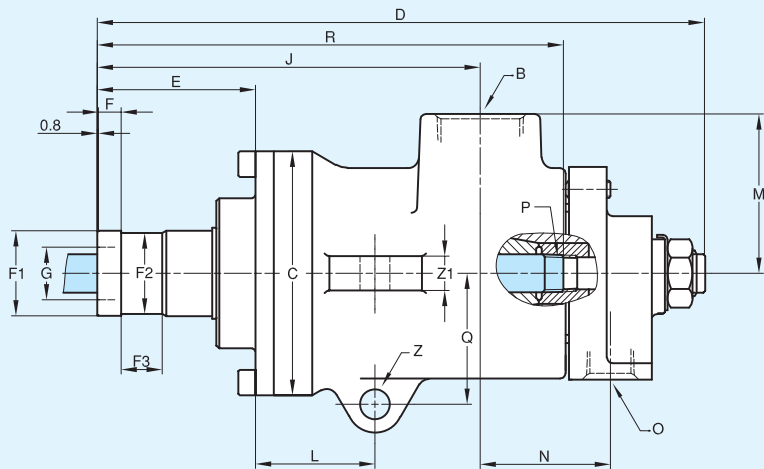
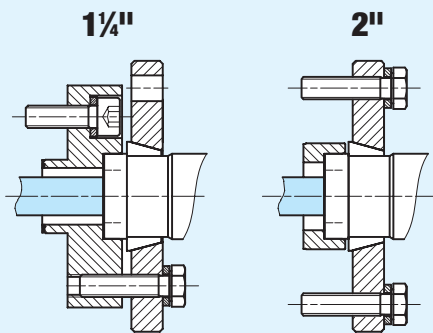

B Port NPT	O Port NPT	Ordering No.	C Ø	D	E	F	F1 Ø	F2	F3	G Ø	J	L	M	N	P	Q	R	Z Ø	Z 1	Shpg. Wt.
1 1/2"	3/4"	C15D-004-02-3A	5 5/8"	13 3/8"	3 15/32"	1/2"	1.870" 1.868"	1.779" 1.775"	29/32"	1 1/16"	8 13/32"	2 5/8"	3 1/2"	2 7/8"	1/2" NPT	2 5/8"	10 1/4"	2 1/2"	1 3/16"	37#