

902 Series "Pop-Off" Rotating Unions for Coolant Service with Dry Running



- Single passage for coolant or MQL
- Patented "pop-off" technology allows unlimited dry running without media pressure
- Full-flow design has no obstructions to trap chips or debris
- Bearing-supported with threaded rotor for easy installation
- Deep groove radial ball bearings for smooth operation
- Labyrinth system and large vents to protect ball bearings
- Balanced mechanical seals made from silicon carbide for long life even under difficult operating conditions
- Anodized aluminum housing resists corrosion

Operating Data

Media	Water-based Coolant MQL (oil mist) up to 10 bar (145 psi)	
Filtration	ISO 4406 Class 17/15/12, max. 60 micron	
Maximum Speed	12,000 min ⁻¹	12,000 rpm
Maximum Pressure	70 bar	1,015 psi
Maximum Flow	82 l/min	21.6 gpm
Maximum Temperature	71°C	160°F



**NO AIR PRESSURE
WITH ROTATION**

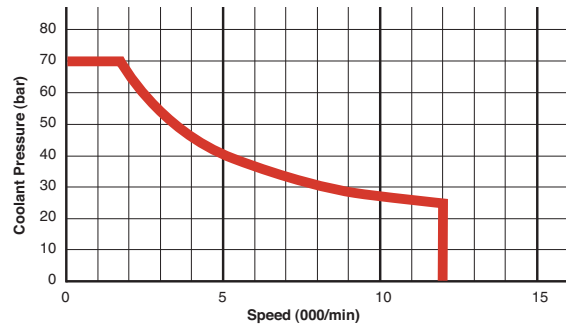

Axial Connection

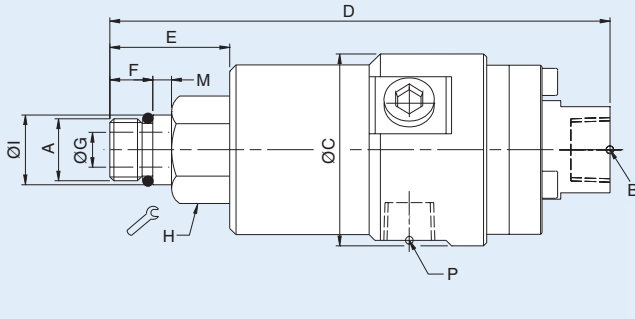

Radial Connection

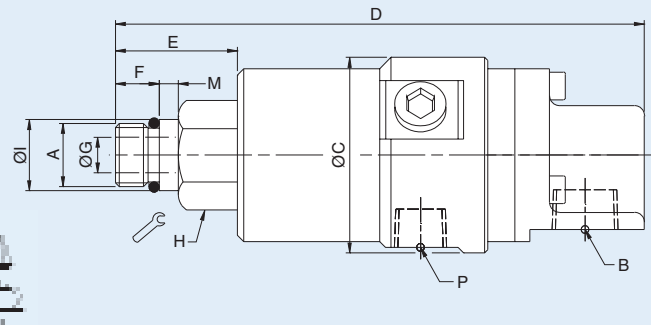

	Ordering Number	B Supply Connection	C Overall Diameter	D Overall Length	P Vent Size (3 x 120°)	A Rotor Connection	E Rotor Length	F Thread Length	G Bore Diameter	H Across Flats	I Pilot Diameter	M Pilot Length
Axial Connection	902-111-165	3/8" NPT	49.5	132	1/4" NPT	5/8"-18 UNF LH	36	15	9	15/16"	0.6555" / 0.6553"	5
	902-121-188	G 3/8"	49.5	129	G 1/4"	M16 x 1.5 LH	33	11	9	24	17.993 / 17.988	5
	902-138-188	G 3/8"	49.5	129	G 1/4"	M16 x 1.5 LH	33	11	9	24	17.993 / 17.988	5
	902-141-188	3/8" PT	49.5	129	1/4" PT	M16 x 1.5 LH	33	11	9	24	17.993 / 17.988	5
Radial Connection	902-110-165	3/8" NPT	49.5	138	1/4" NPT	5/8"-18 UNF LH	36	15	9	15/16"	0.6555" / 0.6553"	5
	902-120-188	G 3/8"	49.5	135	G 1/4"	M16 x 1.5 LH	33	11	9	24	17.993 / 17.988	5
	902-137-188	G 3/8"	49.5	135	G 1/4"	M16 x 1.5 LH	33	11	9	24	17.993 / 17.988	5
	902-140-188	3/8" PT	49.5	135	1/4" PT	M16 x 1.5 LH	33	11	9	24	17.993 / 17.988	5
	902-225-101 ^A	G 3/8"	49.5	135	G 1/4"	Two-Flat 12	26	NA	9	NA	11.984 / 11.966	16
	902-225-104 ^A	G 3/8"	49.5	137	G 1/4"	Female 12	34	NA	9	24	12.027 / 12.000	32
	902-253-220	G 3/8"	46.8	139	G 1/4"	Hexagon 11	34	NA	9	NA	12.984 / 12.957	21

Note A: This union is a bore-mounted design.