

Description

The SRH-11C is a reliable, cost-effective, and proven product that provides excellent performance for many applications. It is a very versatile slip ring due to its unique design. This slip ring can transmit both signal and power effectively. Commonly used on packaging, labelling and filling machines also in combination with rotating union for media transmission.

Model Family	Industry	Application
SRH-11C	Multiple	Packaging, Automation, Rotary Table

Electrical Features

Electrical Channels	Up to 18
Voltage, max	500 VAC/DC for power – 30VDC for signal
Current, max steady state	20 A power, 1 A signal
Data Communication Speed	Up to 10 Mbps for signal
Conductor Ring	Bronze (power) - Silver plated (signal)
Brush Contact	Metal graphite (power) - silver graphite (signal)
Wiring	according power & signal
Connection, stator	Cordgrip
Connection, rotor	Cordgrip

Mechanical Features

Speed, max.	200 RPM
Direction of Rotation	Bi-Directional
IP Rating	IP55
Mounting Orientation	Vertical or Horizontal
Temperature, operating	-20 °C to +70 °C
Temperature, storage	-40 °C to +80 °C
Material, housing	Aluminum
Material, rotor	Aluminum/Galvanized steel
Material, cover	Aluminum



Versions

Standard	3 m long flying leads wire
Options	Connectors, Mounting flanges, flying lead length, threaded hub G 1", customized anti-rotation, internal heater for low temp. application, stainless steel edition (IP67).

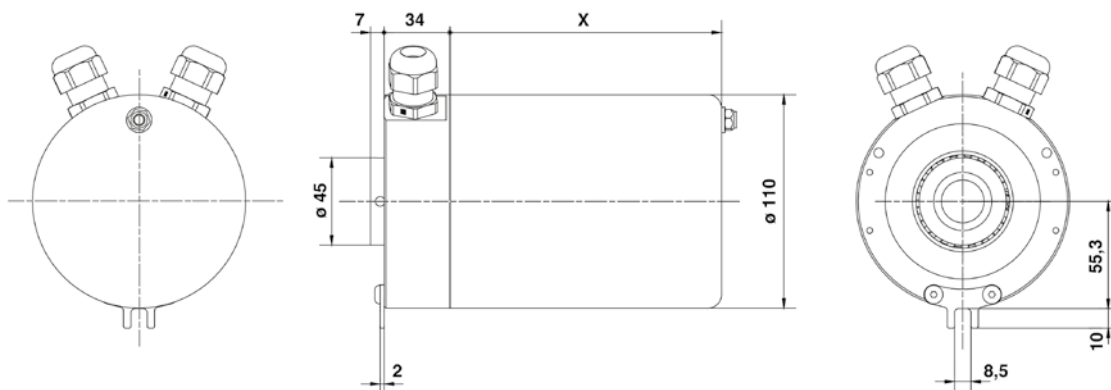
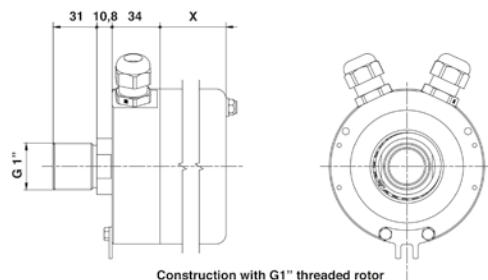

value "X" is depending by channels no.

This series includes additional models.

For more information contact your nearest Deublin Division/Distributor or www.deublin.com