



DEUBLIN

Rotating Union 54 Series

Stainless Steel, DN 10 - 40

- monoflow and duoflow design
- self-supported rotating union
- radial or axial housing connection
- media contacting parts made of stainless steel (from 1.4571)
- full-media flow

For further information please contact **DEUBLIN** or your local representative.

Operating Data

Max. Pressure and max. Speed see Diagram

Max. Temperature 90 °C > 90 °C consult **DEUBLIN**

Temperature > 70°C - max. 90°C only if max. pressure ≤ 10 bar (150 PSI)

At temperatures > 70°C (160°F) media must be liquid (not vaporous)

Seals are Tungsten Carbide/Ceramic

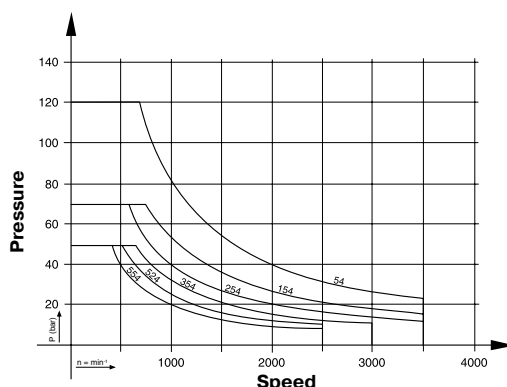

Monoflow Rotating Union with Radial Thread

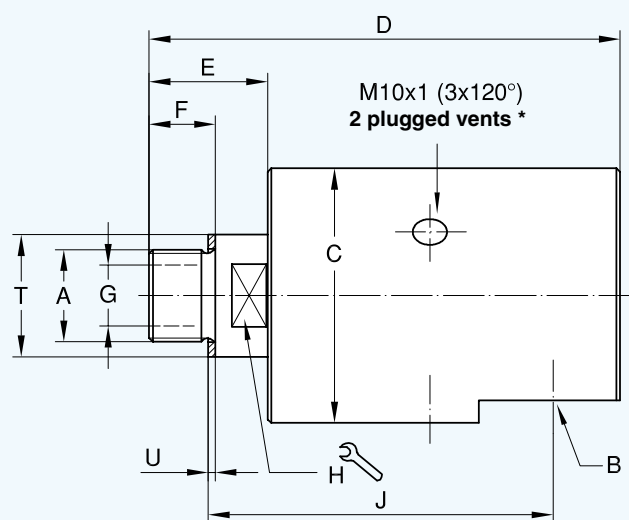

Monoflow Rotating Union with Axial Thread

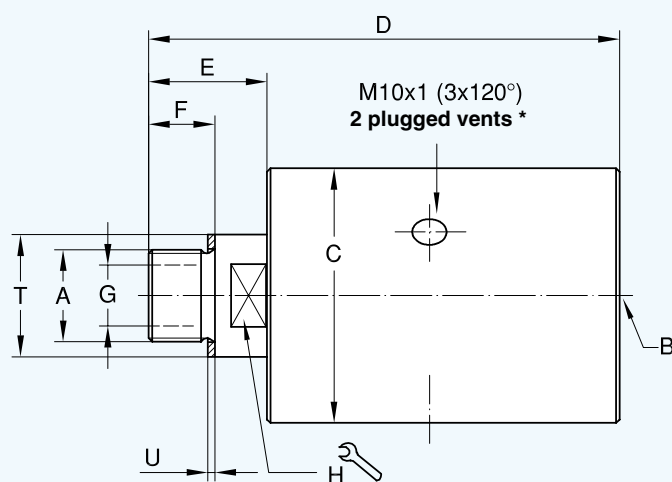

* Adjust open vent downwards, or change one plug respectively

Monoflow Rotating Union

DN	B G	Ordering No.		A Rotor Connections	C ∅	D	E	F	G ∅	H ∅	J ∅ h11	T ∅ h11	U	kg
		Radial	Axial											
10	G 3/8	54-000-110	54-010-110	G 3/8 RH	49	101	26	16	9,5	19	71,5	22	1,5	1,1
	G 3/8	54-000-111	54-010-111	G 3/8 LH	49	101	26	16	9,5	19	71,5	22	1,5	1,1
15	G 1/2	154-000-110	154-010-110	G 1/2 RH	64	123	34	19	12,7	24	89	30	1,5	1,8
	G 1/2	154-000-111	154-010-111	G 1/2 LH	64	123	34	19	12,7	24	89	30	1,5	1,8
20	G 3/4	254-000-110	254-010-110	G 3/4 RH	73	137	36	19	19	30	100	35	2	2,6
	G 3/4	254-000-111	254-010-111	G 3/4 LH	73	137	36	19	19	30	100	35	2	2,6
25	G 1	354-000-110	354-010-110	G 1 RH	94	161	43	22	25	36	117	45	2	5,1
	G 1	354-000-111	354-010-111	G 1 LH	94	161	43	22	25	36	117	45	2	5,1
32	G 1 1/4	524-000-110	524-010-110	G 1 1/4 RH	99	182	54	27	31,8	41	127	50	2	6
	G 1 1/4	524-000-111	524-010-111	G 1 1/4 LH	99	182	54	27	31,8	41	127	50	2	6
40	G 1 1/2	554-000-110	554-010-110	G 1 1/2 RH	108	200	58	29	38	50	138	60	2	8,2
	G 1 1/2	554-000-111	554-010-111	G 1 1/2 LH	108	200	58	29	38	50	138	60	2	8,2