

DEUBLIN

Rotating Union 1109 and 902 Series "POP-OFF" for Coolant Service with Dry-Run Capability, DN 8 and 10 (Patented)

- monoflow design
- self-supported rotating union
- high-wear resistant balanced mechanical seal Silicon Carbide/Silicon Carbide
- during pressureless operation an unlimited run without media is guaranteed by seals that "pop" apart ("POP-OFF")
- high-precision angular contact ball bearings in an X-arrangement
- 902 series with deep-groove radial ball bearings
- effective labyrinth system and large vents protect bearings
- full-media flow
- anodised aluminium housing
- stainless steel rotor
- dry-run under pressureless condition only

For further information please contact **DEUBLIN** or your local representative.

Operating Data

Max. Coolant Pressure*	Model 1109 DN 8	1,520 PSI	105 bar
	1109 DN 10	1,020 PSI	70 bar
	902 DN 10	1,020 PSI	70 bar
Max. Speed*	Model 1109 DN 8	20,000 RPM	20.000 min ⁻¹
	1109 DN 10	15,000 RPM	15.000 min ⁻¹
	902 DN 10	10,000 RPM	10.000 min ⁻¹
Max. Flow Rate	Model 1109 DN 8	4.1 GPM	15 l/min
	1109 DN 10	13.8 GPM	50 l/min
	902 DN 10	13.8 GPM	50 l/min
Max. Temperature	70 °C		> 70 °C consult DEUBLIN

* Operation at max. pressure combined with max. speed is not permissible
Refer to diagram page 50

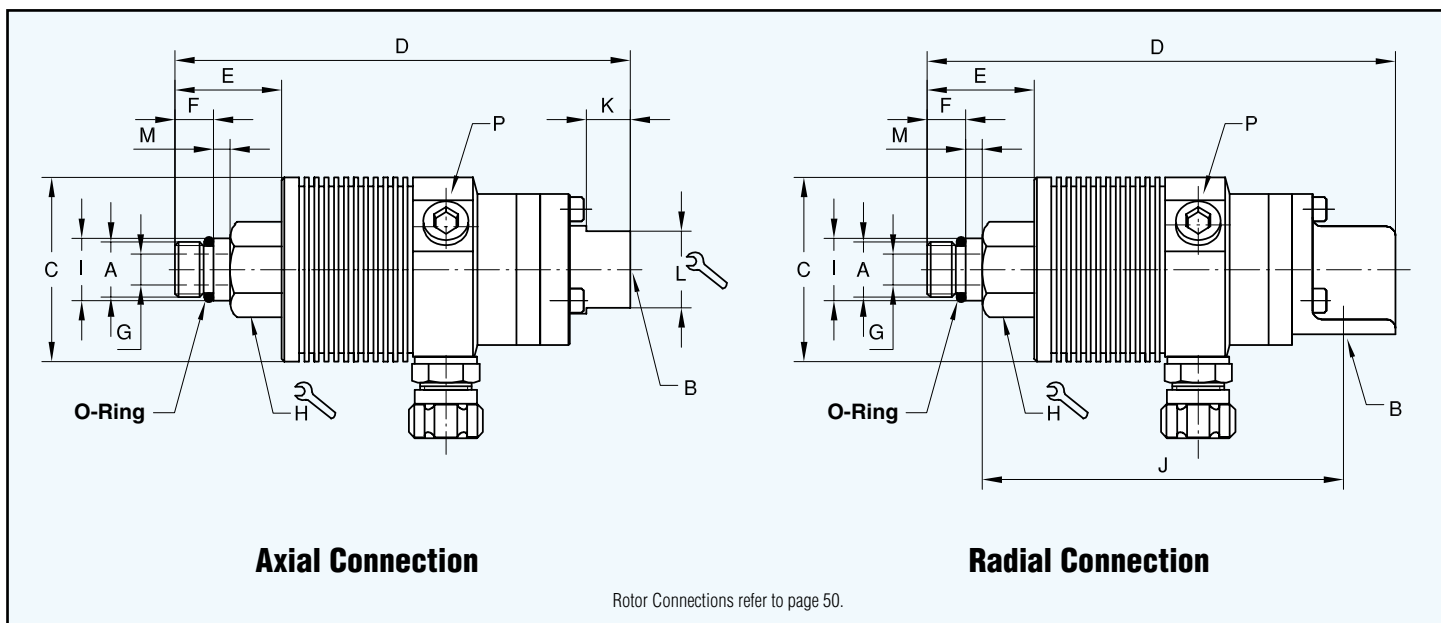

DN	B		Ordering No.	A Rotor Connections	C ø	D	E	F	G ø	H ø	I ø PT	J	K	L ø	M	N	P 3 x 120°	kg
10	G 3/8	Axial Connection	1109-021-188	M 16 x 1,5 LH	53	129	31	11	9	24	17,994 17,989	-	13	22	5	-	G 1/4	0,6
8	G 1/4		1109-024-212	M 16 x 1,5 LH	53	129	31	11	5	24	17,994 17,989	-	13	22	5	-	G 1/4	0,6
10	G 3/8	Radial Connection	1109-020-188	M 16 x 1,5 LH	53	135	31	11	9	24	17,994 17,989	105	-	-	5	-	G 1/4	0,6
8	G 1/4		1109-023-212	M 16 x 1,5 LH	53	135	31	11	5	24	17,994 17,989	105	-	-	5	-	G 1/4	0,6

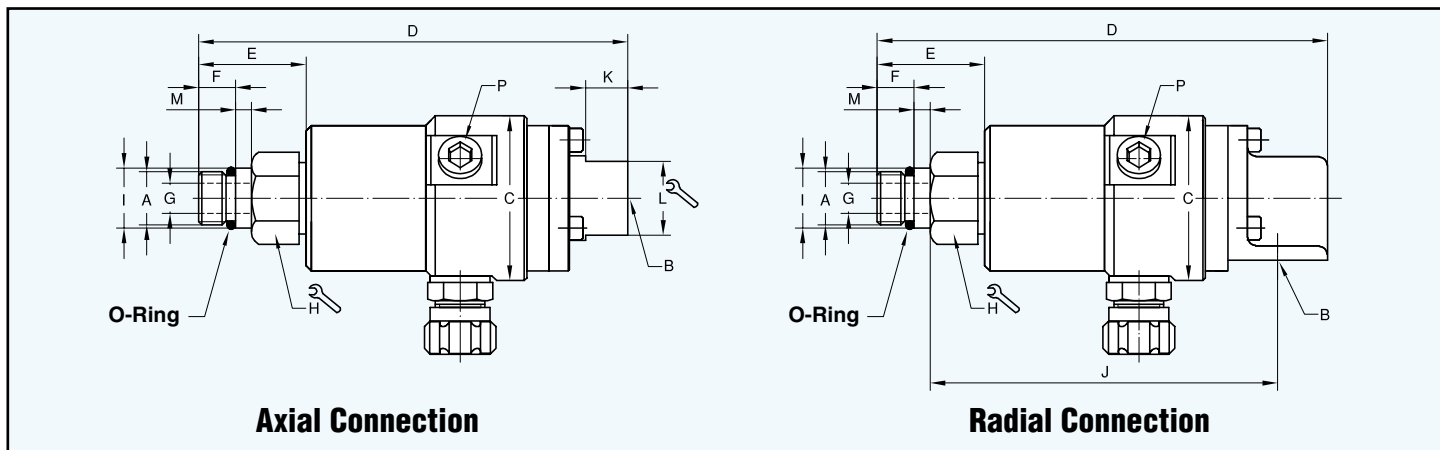

DN	B		Ordering No.	A Rotor Connections	C ø	D	E	F	G ø	H	I ø PT	J	K	L	M	P 3 x 120°	kg
10	G 3/8	Axial	902-121-188	M 16 x 1,5 LH	49,5	129	33	11	9	24	17,994 17,989	-	13	22	5	G 1/4	0,6
10	G 3/8	Radial	902-120-188	M 16 x 1,5 LH	49,5	135	33	11	9	24	17,994 17,989	105	-	-	5	G 1/4	0,6

Operating Data

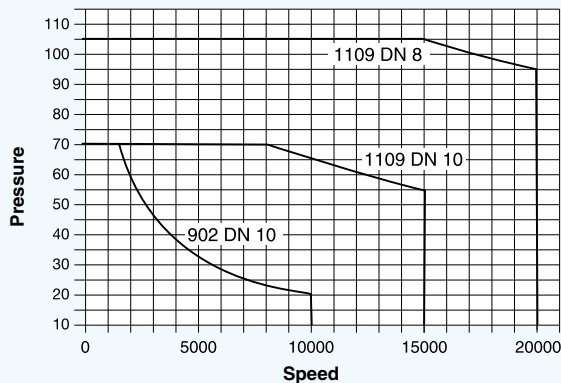

The curves in the adjacent diagram limit pressure and speed in relationship to one another. Within the given area the reliability of the rotating union is guaranteed provided that conditions specified elsewhere are upheld. Simultaneous maximum values are not permissible. For use with deviating parameters permission has to be given by **DEUBLIN**. Otherwise, the warranty is invalidated.

Installation Instructions:

DEUBLIN Coolant Unions are manufactured to precise tolerances for smooth running without vibration or wobble that will shorten union service life. As well as cleanliness when storing and installing the union, a critical factor is the accuracy of the spindle end to which the rotor connects. The interface must adhere to the **DEUBLIN** specifications and to the requirements of fast rotating shafts in the Machine Tool Industry.

Attention!

It is imperative that the drainage is constantly guided downwards. Please refer to "Instructions of Hose Installation" on page 54.

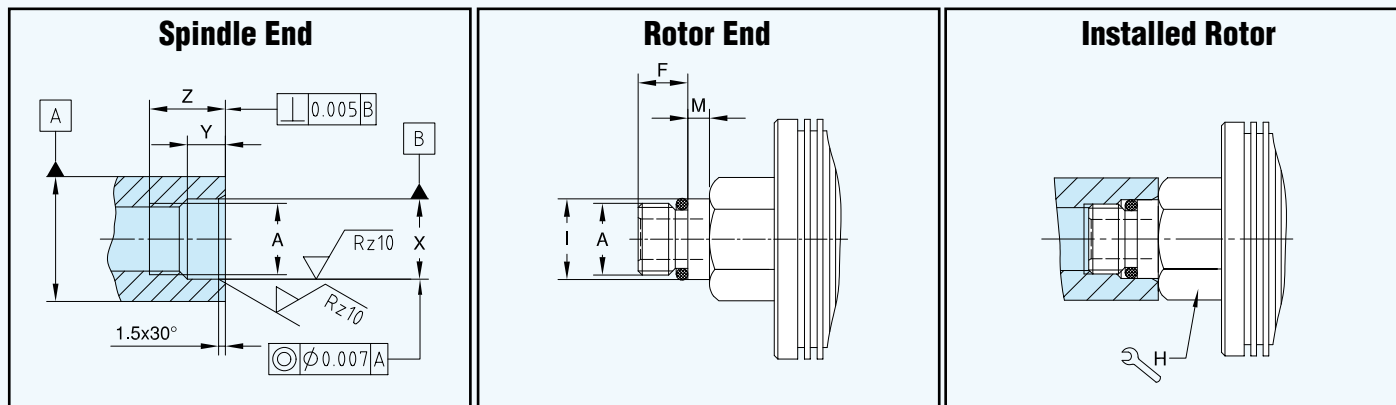

A Rotor Connections	F	H	I ø PT	M	X ø	Y	Z	
M16 x 1,5 LH	11	24	17,994 17,989	5	18,000 17,995	8,5	17	50 Nm