

DEUBLIN

Rotating Union F Series for Water Service, DN 125



- monoflow and duoflow design
- self-supported rotating union
- balanced mechanical seal:
Carbon Graphite/Tungsten Carbide
- two widely spaced ball bearings
- labyrinth seal protects bearings
- nickel-plated cast iron housing
- high corrosion resistant
- steel flange rotor
- on-the-machine seal replacement capability
- inlet/outlet flange:
standard DIN,
optional ANSI, JIS
- special designs up to **DN 300** upon request

Operating Data

Max. Water Pressure*	150 PSI	10 bar
Max. Speed*	750 RPM	750 min ⁻¹
Max. Temperature	120 °C	> 120 °C consult DEUBLIN

* Operation at max. pressure combined with max. speed is not permissible
If operating conditions are marginal, please consult our Engineering Department

For further information please contact **DEUBLIN** or your local representative.

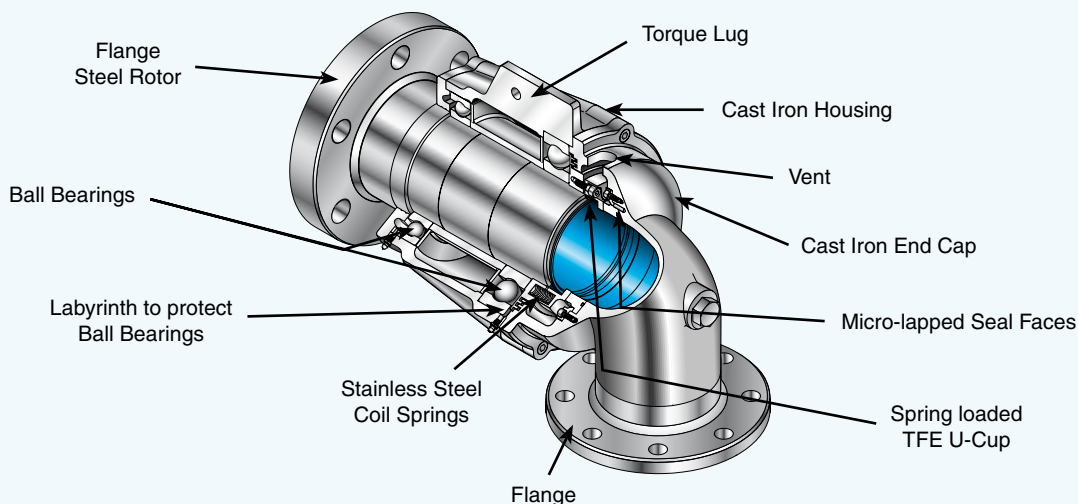

Monoflow Rotating Union

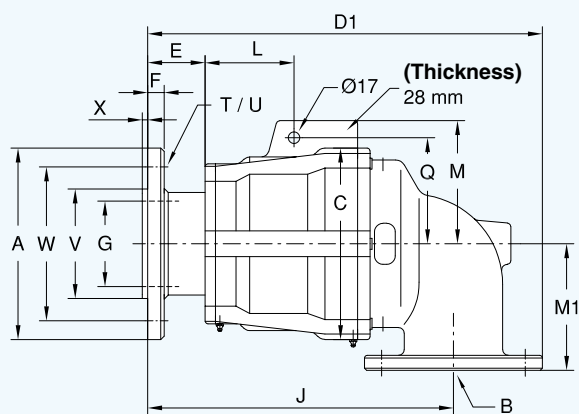

Duoflow Rotating Union

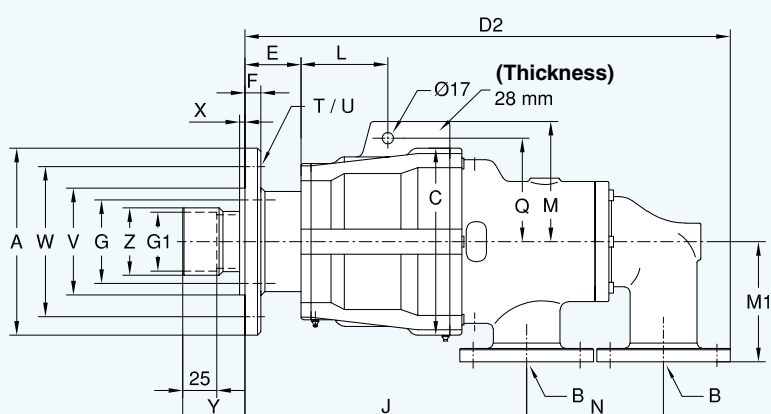

Monoflow Rotating Union

DN	B Flange	Ordering No.	A Ø	C Ø	D1	E	F	G Ø	J	L	M	M ₁	Q	T	U Ø	V Ø PT 1/8	W Ø	X	kg
125	DN 125	F127-004-200	280	280	577	84	25	125	447	130	180	185	155	6 x 60°	18	160	225	8	100

Duoflow Rotating Union

DN	B Flange	Ordering No.	A Ø	C Ø	D2	E	F	G Ø	G ₁ Ø	J	L	M	M ₁	N	Q	T	U Ø	V Ø PT 1/8	W Ø	X	Y	Z Ø	kg
125	2 x DN 80	F127-005-204-701	280	280	727	84	25	125	88,3 +0.1	422	130	180	180	205	155	6 x 60°	18	160	255	8	93	101	120