



DEUBLIN SERIES

Type "C" & "CF"

Steam Duoflow Fixed Siphon

Catalog C2001
High Pressure Steam Duoflow Fixed Siphon

BC-54000 SERIES

Special Design Features

- **Two widely spaced Carbon Bearings provides greater support to the siphon pipe and hoses.**
- **Carbon Seal placed under compression add strength and shock resistance. Joints lasts longer.**
- **External seal wear indicator allows for planned maintenance reducing expensive downtime.**
- **Hardened sleeve and nickel plated end cap provide exceptional life at high pressure.**

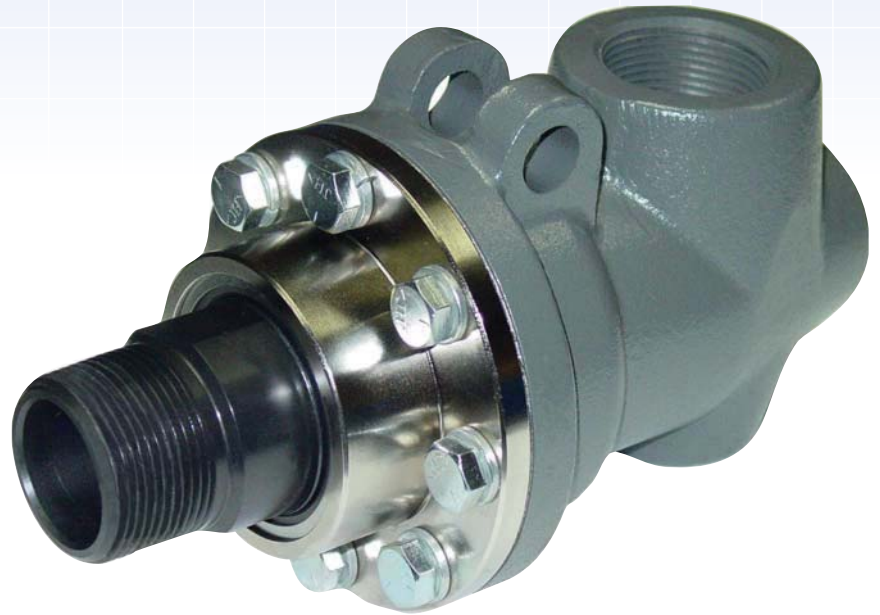

Sizes 1/2" to 3"

Type "C" Ferrrous Trim Rotary Joints are ideal for a wide range of applications using steam. These joints feature an iron casing, ferrous sleeve and end cap, stainless steel spring and spring guides.

The high density carbon seal under compression and widely spaced bearing surfaces assure exceptionally long service life without lubrication. A key maintenance feature is the external seal wear indicator.

Operating Parameters:

Temperature:	+406°F (+208°C)
Pressure Rating:	
Sizes 1/2" to 1-1/2"	250 psi (17.2 BAR)
Sizes 2" to 3"	225 psi (15.5 BAR)

Engineered for Performance

TYPE "C" & "CF"



Ferrous Trim Construction
Recommended for higher pressure steam
to 250 psi (17.2 BAR)

For BSPT threads:

Add a "B" to the end of the part number.

Example: BC-54000-08-50B

*BSPT Models are not supplied with siphon bushing

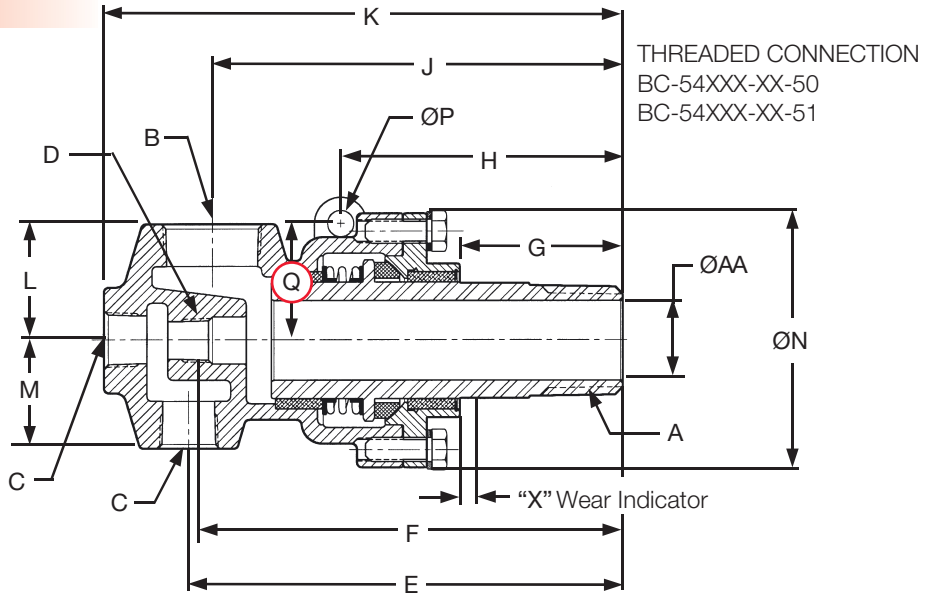

Joint Size	Ferrous Trim Part Number	A NPT	B NPT	øAA	C NPT	D Siphon Thread NPT	D Siphon Thd With Bushing*	E	F	G	H	J	K
1/2"	BC-54000-08-50	1/2" R.H.	1/2"	Ø.50"	1/4"	1/8"	—	5.37"	5.06"	1.73"	—	4.54"	5.87"
	BC-54000-08-51	1/2" L.H.	1/2"	Ø.50"	1/4"	1/8"	—	5.37"	5.06"	1.73"	—	4.54"	5.87"
3/4"	BC-54000-12-50	3/4" R.H.	3/4"	Ø.75"	1/2"	1/4"	1/8"	5.16"	5.25"	1.68"	—	4.54"	6.17"
	BC-54000-12-51	3/4" L.H.	3/4"	Ø.75"	1/2"	1/4"	1/8"	5.16"	5.25"	1.68"	—	4.54"	6.17"
1"	BC-54000-16-50	1" R.H.	1"	Ø1.00"	1/2"	3/8"	1/4"	5.96"	6.04"	2.03"	4.01"	5.21"	7.01"
	BC-54000-16-51	1" L.H.	1"	Ø1.00"	1/2"	3/8"	1/4"	5.96"	6.04"	2.03"	4.01"	5.21"	7.01"
	BC-54000-16-60	CF	1"	Ø1.00"	1/2"	3/8"	1/4"	6.69"	6.78"	2.77"	4.75"	5.94"	7.75"
	BC-54000-16-62	QR	1"	Ø1.00"	1/2"	3/8"	1/4"	6.70"	6.79"	2.78"	4.76"	5.95"	7.76"
1 1/4"	BC-54000-20-50	1 1/4" R.H.	1 1/4"	Ø1.25"	3/4"	1/2"	3/8"	6.99"	7.25"	1.89"	4.37"	6.68"	8.60"
	BC-54000-20-51	1 1/4" L.H.	1 1/4"	Ø1.25"	3/4"	1/2"	3/8"	6.99"	7.25"	1.89"	4.37"	6.68"	8.60"
	BC-54000-20-62	QR	1 1/4"	Ø1.25"	3/4"	1/2"	3/8"	8.55"	8.81"	3.45"	5.93"	8.24"	10.16"
1 1/2"	BC-54000-24-50	1 1/2" R.H.	1 1/2"	Ø1.50"	3/4"	3/4"	1/2"	7.48"	7.53"	2.12"	4.72"	7.04"	9.03"
	BC-54000-24-51	1 1/2" L.H.	1 1/2"	Ø1.50"	3/4"	3/4"	1/2"	7.48"	7.53"	2.12"	4.72"	7.04"	9.03"
	BC-54000-24-60	CF	1 1/2"	Ø1.50"	3/4"	3/4"	1/2"	8.89"	8.94"	3.53"	6.13"	8.45"	10.45"
	BC-54000-24-62	QR	1 1/2"	Ø1.50"	3/4"	3/4"	1/2"	8.89"	8.94"	3.53"	6.13"	8.45"	10.45"
2"	BC-54000-32-50	2" R.H.	2"	Ø1.88"	1 1/4"	3/4"	1/2"	8.62"	8.62"	2.19"	5.01"	8.06"	10.63"
	BC-54000-32-51	2" L.H.	2"	Ø1.88"	1 1/4"	3/4"	1/2"	8.62"	8.62"	2.19"	5.01"	8.06"	10.63"
	BC-54000-32-60	CF	2"	Ø1.88"	1 1/4"	3/4"	1/2"	10.09"	10.08"	3.66"	6.48"	9.53"	12.10"
	BC-54000-32-62	QR	2"	Ø1.88"	1 1/4"	3/4"	1/2"	9.71"	9.71"	3.28"	6.10"	9.15"	11.72"
2 1/2"	BC-54000-40-50	2 1/2" R.H.	2 1/2"	Ø2.25"	1 1/4"	1"	3/4"	10.14"	10.24"	2.91"	6.33"	9.76"	12.45"
	BC-54000-40-51	2 1/2" L.H.	2 1/2"	Ø2.25"	1 1/4"	1"	3/4"	10.14"	10.24"	2.91"	6.33"	9.76"	12.45"
	BC-54000-40-60	CF	2 1/2"	Ø2.25"	1 1/4"	1"	3/4"	10.09"	10.56"	3.66"	6.48"	9.53"	12.10"
	BC-54000-40-62	QR	2 1/2"	Ø2.25"	1 1/4"	1"	3/4"	10.77"	10.86"	3.54"	6.96"	10.39"	13.08"
3"	BC-54000-48-50	3" R.H.	3"	Ø2.88"	1 1/2"	1 1/2"	1"	10.86"	11.03"	3.05"	6.60"	10.67"	13.04"
	BC-54000-48-51	3" L.H.	3"	Ø2.88"	1 1/2"	1 1/2"	1"	10.86"	11.03"	3.05"	6.60"	10.67"	13.04"
	BC-54000-48-60	CF	3"	Ø2.88"	1 1/2"	1 1/2"	1"	11.35"	11.53"	3.55"	7.10"	11.16"	13.53"
	BC-54000-48-62	QR	3"	Ø2.88"	1 1/2"	1 1/2"	1"	11.36"	11.53"	3.55"	7.10"	11.16"	13.54"

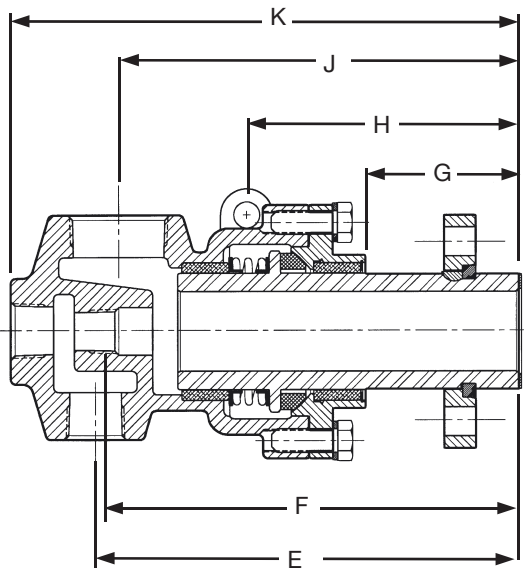

"CF" CONNECTION
BC-54XXX-XX-60

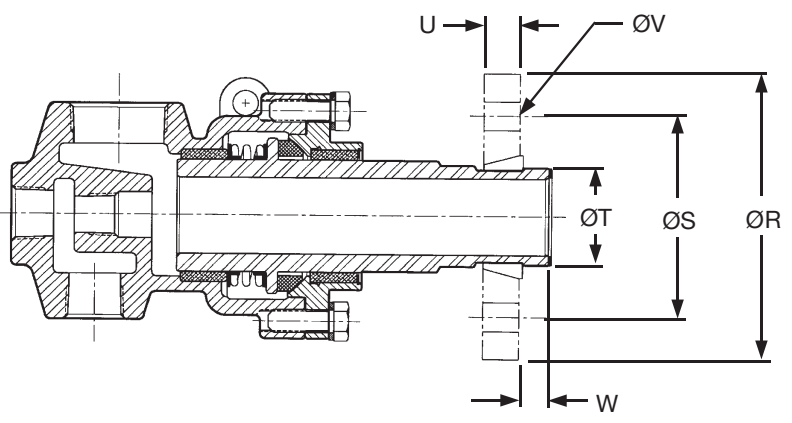

QUICK RELEASE CONNECTION
BC-54XXX-XX-62

L	M	ØN	ØP	Torque Rod O.D. Max.	Q	ØR	ØS	ØT	U	4X ØV	W	"X"	Weight	Joint Size
1.62"	1.16"	Ø3.00"	—	—	—	—	—	—	—	—	—	.19"	3.5 lbs	1/2"
1.62"	1.16"	Ø3.00"	—	—	—	—	—	—	—	—	—	.19"	3.5 lbs	
1.75"	1.25"	Ø3.38"	—	—	—	—	—	—	—	—	—	.19"	5 lbs.	3/4"
1.75"	1.25"	Ø3.38"	—	—	—	—	—	—	—	—	—	.19"	5 lbs.	
2.06"	1.25"	Ø3.62"	Ø.50"	Ø.38"	1.75"	—	—	—	—	—	—	.25"	6 lbs.	1"
2.06"	1.25"	Ø3.62"	Ø.50"	Ø.38"	1.75"	—	—	—	—	—	—	.25"	6 lbs.	
2.06"	1.25"	Ø3.62"	Ø.50"	Ø.38"	1.75"	Ø3.88"	Ø2.75"	Ø1.399"-1.401"	.75"	Ø.56"	1.092"	.25"	9 lbs.	
2.06"	1.25"	Ø3.62"	Ø.50"	Ø.38"	1.75"	Ø5.00"	Ø3.12"	Ø1.276"-1.278"	.56"	Ø.56"	.438"	.25"	9 lbs.	
2.19"	1.78"	Ø4.38"	Ø.62"	Ø.50"	2.09"	—	—	—	—	—	—	.25"	13 lbs	1 1/4"
2.19"	1.78"	Ø4.38"	Ø.62"	Ø.50"	2.09"	—	—	—	—	—	—	.25"	13 lbs	
2.19"	1.78"	Ø4.38"	Ø.62"	Ø.50"	2.09"	Ø5.50"	Ø3.50"	Ø1.620"-1.622"	.62"	Ø.56"	.50"	.25"	18 lbs.	
2.44"	2.06"	Ø4.75"	Ø.62"	Ø.50"	2.26"	—	—	—	—	—	—	.25"	15 lbs	1 1/2"
2.44"	2.06"	Ø4.75"	Ø.62"	Ø.50"	2.26"	—	—	—	—	—	—	.25"	15 lbs	
2.44"	2.06"	Ø4.75"	Ø.62"	Ø.50"	2.26"	Ø4.88"	Ø3.62"	Ø2.091"-2.093"	.75"	Ø.69"	1.092"	.25"	19 lbs	
2.44"	2.06"	Ø4.75"	Ø.62"	Ø.50"	2.26"	Ø5.50"	Ø3.88"	Ø1.872"-1.870"	.69"	Ø.56"	.50"	.25"	19 lbs.	
2.75"	2.56"	Ø6.00"	Ø.62"	Ø.50"	2.76"	—	—	—	—	—	—	.31"	26 lbs	2"
2.75"	2.56"	Ø6.00"	Ø.62"	Ø.50"	2.76"	—	—	—	—	—	—	.31"	26 lbs	
2.75"	2.56"	Ø6.00"	Ø.62"	Ø.50"	2.76"	Ø5.50"	Ø4.25"	Ø2.714"-2.716"	.75"	Ø.69"	1.092"	.31"	31 lbs	
2.75"	2.56"	Ø6.00"	Ø.62"	Ø.50"	2.76"	Ø6.81"	Ø4.75"	Ø2.318"-2.320"	.75"	Ø.56"	.625"	.31"	34 lbs.	
3.00"	2.50"	Ø6.75"	Ø.75"	Ø.62"	3.06"	—	—	—	—	—	—	.25"	33 lbs.	2 1/2"
3.00"	2.50"	Ø6.75"	Ø.75"	Ø.62"	3.06"	—	—	—	—	—	—	.25"	33 lbs.	
3.00"	2.50"	Ø6.75"	Ø.75"	Ø.62"	3.06"	Ø5.88"	Ø4.62"	Ø3.089"-3.091"	.75"	Ø.75"	1.092"	.25"	40 lbs	
3.00"	2.50"	Ø6.75"	Ø.75"	Ø.62"	3.06"	Ø6.75"	Ø4.75"	Ø2.838"-2.840"	.88"	Ø.56"	.75"	.25"	42 lbs.	
3.62"	2.88"	Ø7.88"	Ø.94"	Ø.75"	3.62"	—	—	—	—	—	—	.25"	45 lbs.	3"
3.62"	2.88"	Ø7.88"	Ø.94"	Ø.75"	3.62"	—	—	—	—	—	—	.25"	45 lbs.	
3.62"	2.88"	Ø7.88"	Ø.94"	Ø.75"	3.62"	Ø6.50"	Ø5.25"	Ø3.714"-3.716"	.75"	Ø.69"	1.092"	.25"	50 lbs	
3.62"	2.88"	Ø7.88"	Ø.94"	Ø.75"	3.62"	Ø8.00"	Ø6.75"	Ø3.430"-3.732"	.94"	Ø.69"	.88"	.25"	57 lbs.	

CF Connection

BC-54XXX-XX-60

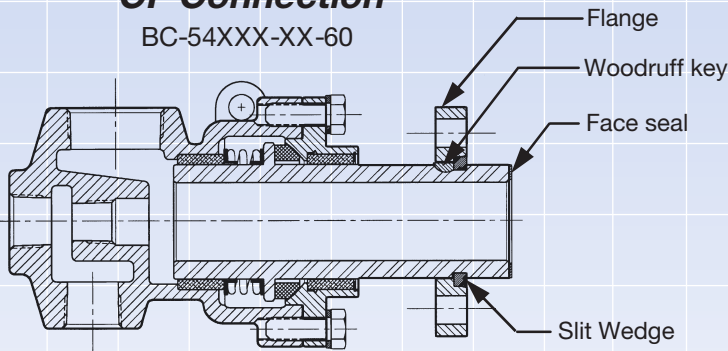

Quick Release Connection

BC-54XXX-XX-62

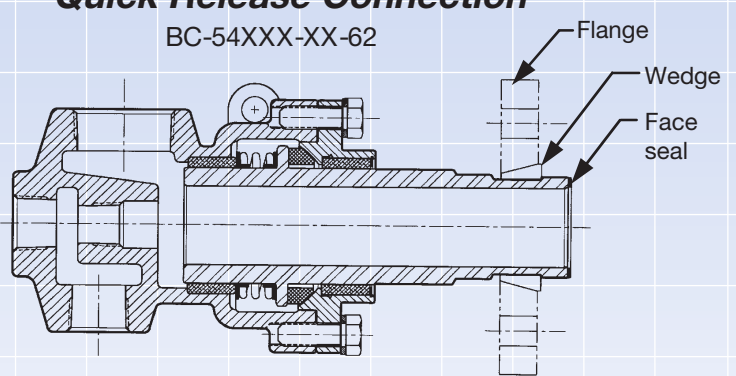

Journal Dimensions

Joint size	CF Connection		Quick Release Connection	
	ØA	B	ØA	B
1"	Ø1.408"-1.406"	1.052"	Ø1.283"-1.279"	.312"
1 1/4"	--	1.052"	Ø1.624"-1.623"	.375"
1 1/2"	Ø2.099"-2.096"	1.052"	Ø1.877"-1.873"	.375"
2"	Ø2.724"-2.721"	1.052"	Ø2.325"-2.321"	.500"
2 1/2"	Ø3.099"-3.096"	1.052"	Ø2.845"-2.841"	.625"
3"	Ø3.724"-3.721"	1.052"	Ø3.439"-3.435"	.875"

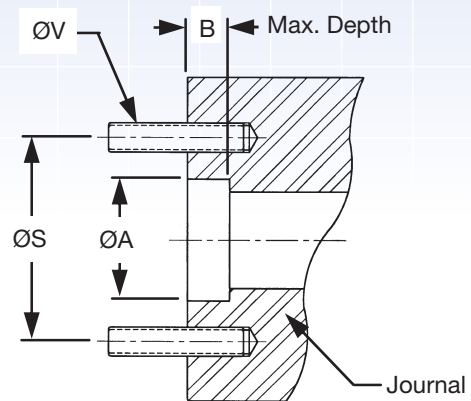

Quick Release Flanges and split wedges are available. Contact DEUBLIN for more information.

Repair Kits

Joint Size	Part Number
1/2"	10-27274-00
3/4"	10-27275-00
1"	10-27276-00
1 1/4"	10-27277-00
1 1/2"	10-27278-00
2"	10-27279-00
2 1/2"	10-27280-00
3"	10-27281-00

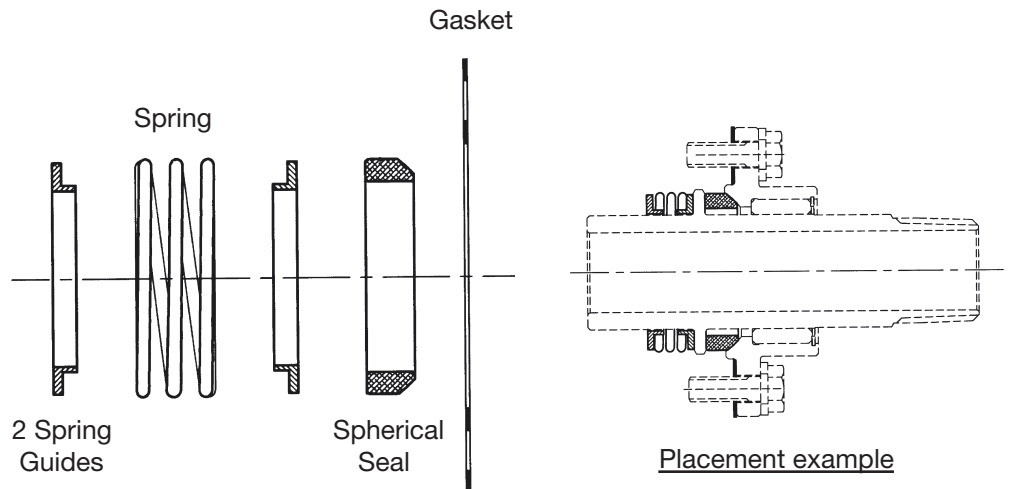

信德迈科技(北京)有限公司CNMEC Technology
 地址：北京市朝阳区望京SOHO-T1-C座2115室
 邮编：100029
 电话：010-8428 2935，8428 3983
 传真：010-8428 8762
 主页：//www.cnmec.net
 电子邮件：sales@cnmec.biz