

DEUBLIN

1117 Series Bearingless "Closed Seal" Rotating Unions for Continuous Coolant Service

- Single passage for coolant or MQL
- Closed seals for transfer line and similar applications
- Full-flow design has no obstructions to trap swarf or debris
- Balanced mechanical seals made from silicon carbide for long life even under difficult operating conditions
- Compact size can be adapted for custom installations
- Anodised aluminium housing resists corrosion
- Designs acc. to DIN ISO 69002 available; see table



Operating Data

Media	Water-based Coolant MQL (oil mist) up to 10 bar (145 psi)		
Filtration	ISO 4406 Class 17/15/12, max. 60 micron		
Max. Speed	see chart/table		
Max. Pressure	see chart		
Max. Flow	82 l/min	21.6 gpm	Standard
	24,3 l/min	6.4 gpm	High Pressure (HP)
	2,7 l/min	0.7 gpm	Very High Pressure (VHP)
Max. Temperature	71 °C	160 °F	



DO NOT RUN DRY

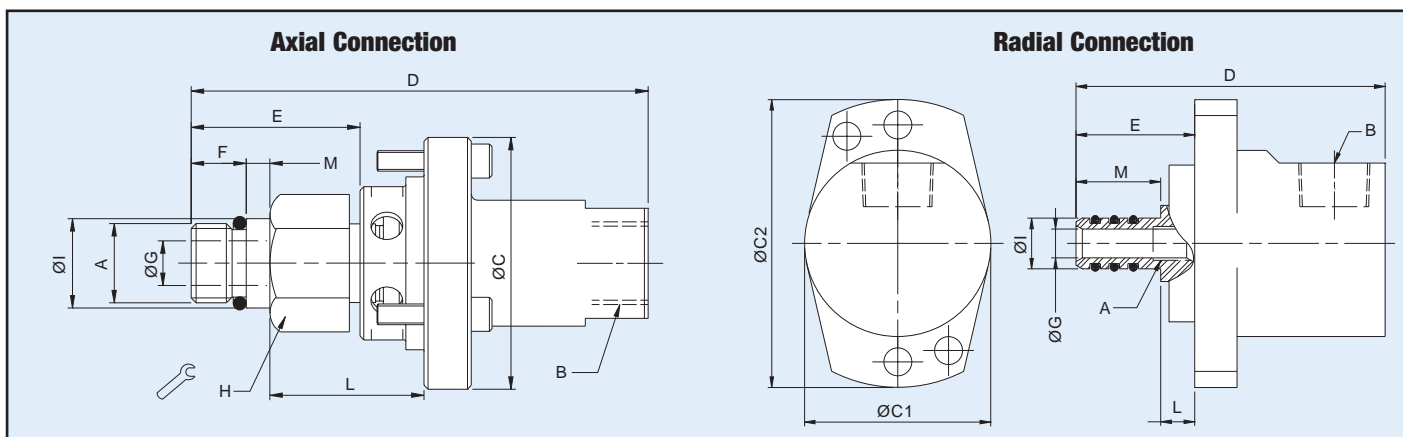
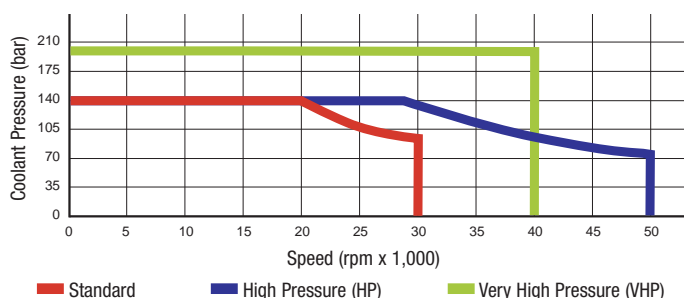

		Ordering Number	B Supply Connection	C Overall Diameter	D Overall Length	L Mounting Distance	A Rotor Connection	E Rotor Length	G Bore Diameter	H Across Flats	I Pilot Diameter	M Pilot Length	Max. Speed (rpm)	
Standard	Radial	1117-711 ^A	3/8 NPT	44 x 68	73	8.0 / 7.5	12 f7	28	7	–	11.984 / 11.966	20	10,000	
		1117-792	G 3/8	44	72	7.5 / 7.0	12 f7	21	7	–	11.984 / 11.966	20	30,000	
	Axial Connection	1117-002-116	3/8 NPT	51	92	31.7 / 30.5	M16 x 1.5 LH	34	9	24	17.993 / 17.988	5	30,000	
		1117-058-116	G 3/8	51	92	31.7 / 30.5	M16 x 1.5 LH	34	9	24	17.993 / 17.988	5	30,000	
DIN ISO 69002	Axial Connection	1117-789	25 f7	36 x 52	56	23.7 / 23.3	12 f7	28	7	–	11.984 / 11.996	20	30,000	
		1117-571-572	G 3/8	44	67.5	11.5	M14 x 15 LH	16	Tube-I Ø4	22	15.993 / 15.988	5	30,000	
		1117-571-573	G 3/8	44	67.5	11.5	M14 x 15 LH	16	Tube-I Ø5	22	15.993 / 15.988	5	30,000	
		1117-571-574	G 3/8	44	67.5	11.5	M14 x 15 LH	16	Tube-I Ø6	22	15.993 / 15.988	5	30,000	
		1117-571-575	G 3/8	44	67.5	11.5	M16 x 15 LH	16	Tube-I Ø8	22	17.993 / 17.988	5	30,000	
		HP	1117-490-493	3/8 PT	54	105	39.6 / 38.6	M12 x 1.25 LH	40	5	18	14.000 / 13.995	5	50,000
		VHP	1117-063-294	G 1/4	51	92	31.7 / 30.5	M16 x 1.5 LH	34	5	24	17.993 / 17.988	5	40,000

Note A: Union includes integral lip seals for added spindle protection.