



# DEUBLIN

## 1101 Series "Closed Seal" Rotating Unions for Continuous Coolant Service

- Single passage for coolant or MQL
- Closed seals for transfer line and similar applications
- Full-flow design has no obstructions to trap swarf or debris
- Bearing-supported with threaded rotor for easy installation
- Deep groove radial ball bearings for smooth operation
- Labyrinth system and large vents to protect ball bearings
- Balanced mechanical seals made from silicon carbide for long life even under difficult operating conditions
- Anodised aluminium components resist corrosion

### Operating Data

Media	Water-based Coolant MQL (oil mist) up to 10 bar (145 psi)	
Filtration	ISO 4406 Class 17/15/12, max. 60 micron	
Max. Speed	15.000 min <sup>-1</sup>	15,000 rpm
Max. Pressure	105 bar	1,523 psi
Max. Flow	20 l/min	5.3 gpm
Max. Temperature	71 °C	160 °F



DO NOT RUN DRY

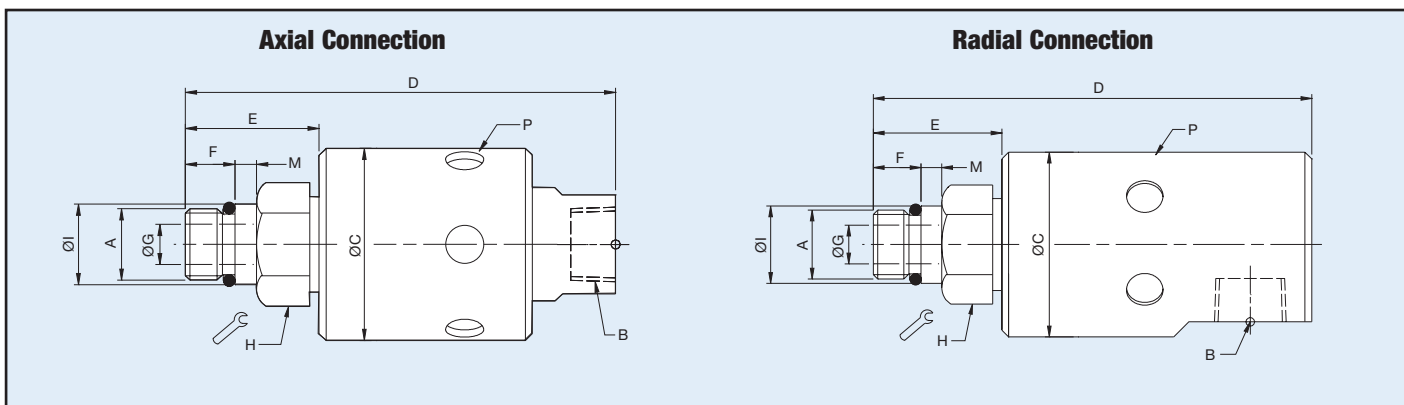
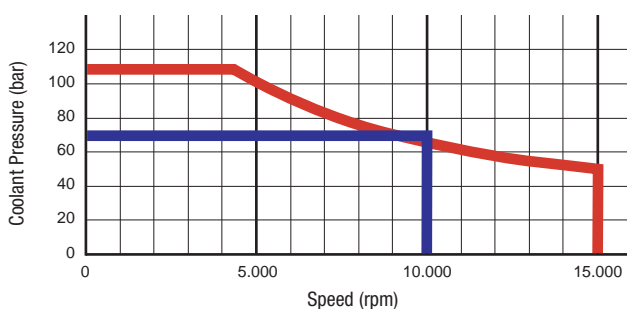

	Ordering Number	B Supply Connection	C Overall Diameter	D Overall Length	P Vent Size Ø (6 x 60°)	A Rotor Connection	E Rotor Length	F Thread Length	G Bore Diameter	H Across Flats	I Pilot Diameter	M Pilot Length
Axial	1101-235-238	3/8 NPT	43	100	9	5/8-18 UNF LH	33	14	6	15/16"	0.6555" / 0.6553"	5
	1101-235-239	3/8 NPT	43	100	9	5/8-18 UNF RH	33	14	6	15/16"	0.6555" / 0.6553"	5
	1101-235-343	3/8 NPT	43	96	9	M16 x 1.5 LH	30	11	6	24	17.993 / 17.988	5
	1101-235-424	3/8 NPT	43	93	9	M10 x 1 LH	27	11	3.2	24	10.994 / 10.989	3
	1101-359-343	G 3/8	43	96	9	M16 x 1.5 LH	30	11	6	24	17.993 / 17.988	5
R.	1101-195-343	G 3/8	43	102	9	M16 x 1.5 LH	30	11	6	24	17.993 / 17.988	5
Radial	1101-265-343*	G 1/4	43	95	3 x R 1/8	M16 x 1.5 LH	30	11	6	24	17.993 / 17.988	5
	1101-265-644*	G 1/4	43	91	3 x R 1/8	Flange TK-Ø 21	26	14.5	6	4 x M4	Ø 30.01 H6	8

\* Also allowed for hydraulics, compressed air and defined dry run cycles. For further information please contact DEUBLIN.