

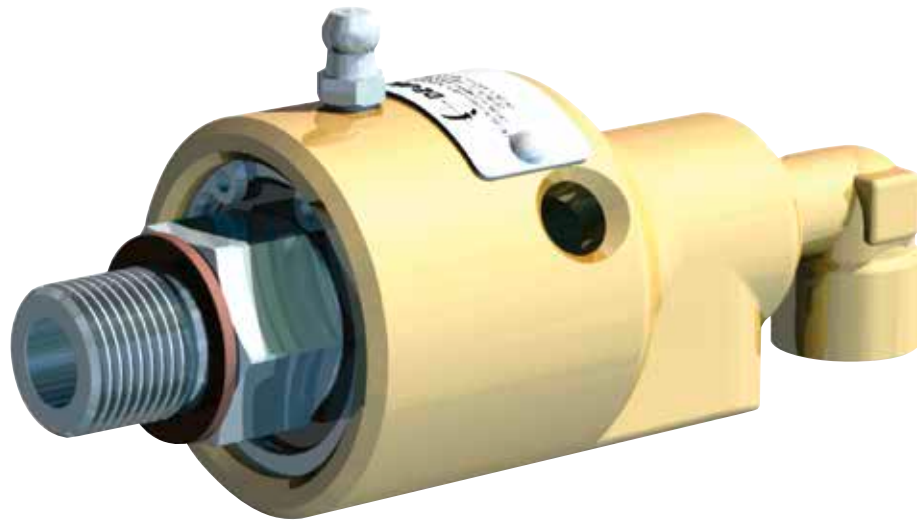

Rotating Unions



Series

54

55

57

Model

54
154
254
354
524
554

55
155
255
355
525
555
655
755

57
157
257
357
527
557
657
857

Exception: The present Operating Manual is not applicable for the following models. Those are described in particular Operating Manuals.

040-550-1 555-413-xxx
655-905-xxx
655-921-xxx
655-952-xxx

040-550-2 655-969-xxx

040-550-3 55-283-xxx
155-339-xxx
255-156-xxx
355-062-xxx
525-171-xxx
555-087-xxx
555-542-xxx

Content

1	For your Safety	3
1.1	Intended Use	3
1.1.1	Application one-way version (Mono)	4
1.1.2	Application two-way version (Duo)	5
1.2	Misuse	5
1.3	Safety Instructions	6
1.3.1	Hazards due to hot surfaces	6
1.3.2	Hazards by improper hoses	6
1.3.3	Hazards due to the media	6
1.3.4	Hazards by faulty installation	6
1.4	Structure of Pictograms	7
2	Information as to this Manual	7
3	Information on the Name Plate	7
4	Information on the Design	8
4.1	Filtering of the Medium	8
4.2	Connecting Options of the Rotating Union at the Machine Shaft	8
4.3	Options of Hose Installation	8
4.3.1	Connection of hose to the rotating union	9
4.3.2	Hose connection in case of additional axial movement of the machine shaft	9
4.3.3	Hose connection for hoses with SAE flange	10
4.3.4	Optional: Connection of a leakage line	10
5	Installation	11
6	Information on the Operation	11
7	Storage	11
8	Maintenance	11
8.1	Maintenance Intervals	11
8.2	Daily Inspection	12
8.3	Maintenance after Operating Hours	12
8.3.1	Allowed lubricants	13
8.3.2	Volume of grease for lubrication	13
8.3.3	Relubrication intervals for series 55 and models 857	13
8.3.4	Relubrication intervals for 55 Hot Package series	15
8.3.5	Lubricate the rotating union	15
9	Trouble Shooting	15
9.1	Potential Causes for Errors and their Elimination	15
9.2	Pack Rotating Union for Transport	16
10	Disposal	17
10.1	Dispose of Packaging	17
10.2	Dispose of Rotating Union	17
11	Spare Parts	17

1 For your Safety

This chapter provides information on the safe handling of *DEUBLIN* rotating unions.

- For your own safety and the safety of other people read this operating manual carefully and completely prior to working on or with *DEUBLIN* rotating unions.
- This operating manual exclusively describes the rotating unions of the manufacturer *DEUBLIN*. In the further description/explanation the name “*DEUBLIN*” is left out for a better readability.
- This operating manual is a material part of the specified rotating unions. The operator is responsible for the personnel to take note of this manual.
- Always use the latest version of the operating manual, available under www.deublin.eu.
- The operator of the rotating unions shall not make any modifications or attachments to and retrofitting of the rotating union without the manufacturer’s consent.
- Please follow the additional instruction „Installation“ for a secure and correct installation of the rotating union. The installation instruction is included with the delivered union.

1.1 Intended Use

The rotating unions of the series 54, 55 and 57 supply the feeding of the following media: Water, steam (not for series 55 Hot Package), thermal oil

Series	Model	Temperature range (°C)	Medium		
			Water	Steam (short-term saturated steam)	Thermal oil
54		up to 90°	•		
55	55 up to 655	up to 120°	•	•	•
55 Hot Package ¹⁾	55 up to 655	up to 160°	•		•
55	755	up to 120°	•	•	
55 Hot Package ¹⁾	755	up to 160°	•		
57		up to 90°	•		
57	857	up to 120°	•		

¹⁾ Hot Package models are suitable either for hot water or thermal oil.

The rotating unions referred to are designed for non-potentially explosive environments and non-combustible media. Details on the operating range of the rotating unions are provided in the catalogue and/or the model-specific installation drawing.

The rotating unions of the series 54, 55 and 57 can be used as one-way or two-way version depending on the type of connection.

Please note: Several special models are available for the use of other media (e.g. air), but the present operating manual does not apply to these models. Please contact *DEUBLIN* if you want to use other media.

1.1.1 Application one-way version (Mono)

For the one-way version, models are available which can be installed at the machine shaft from the outside or in the machine shaft.

Rotating union externally mounted

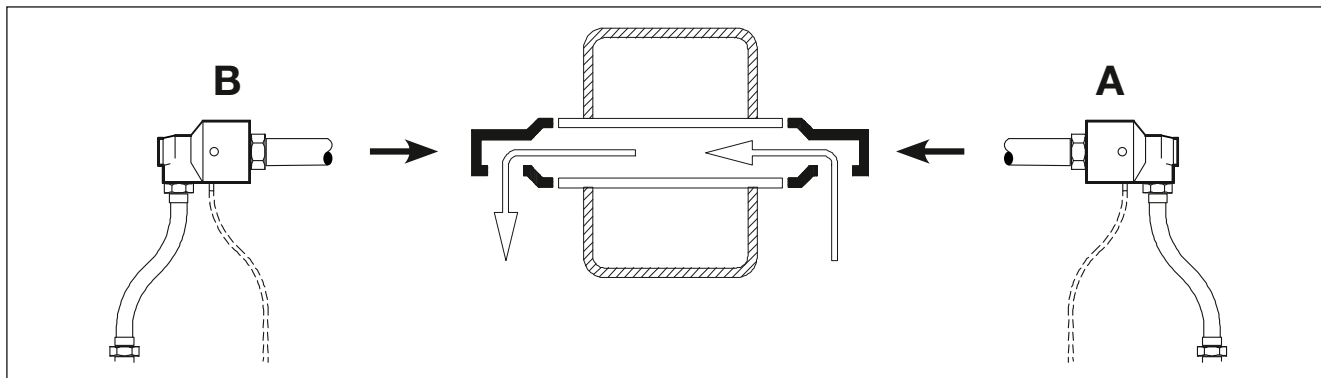

Fig. 1: Schematic diagram one-way version (Mono – externally mounted)

One one-way version of the rotating union is mounted at each of the two ends of the roller. The rotating union **(A)** conveys the medium into the roller. The rotating union **(B)** conveys the medium into the piping system of the machine.

Rotating union in-the-shaft-mounted

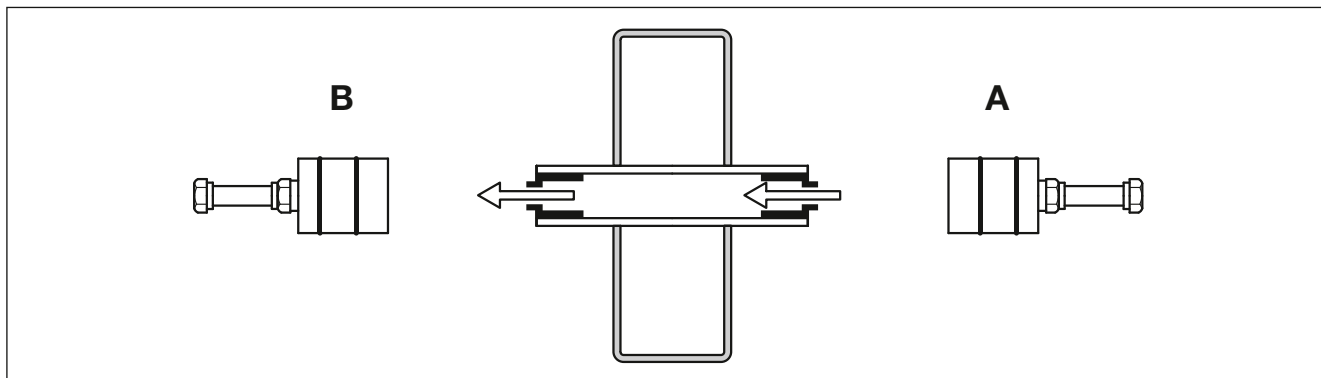

Fig. 2: Schematic diagram one-way version (Mono – in-the-shaft mounted)

One one-way version of the rotating union is mounted in each of the two ends of the roller. The rotating union **(A)** conveys the medium into the roller. The rotating union **(B)** conveys the medium into the piping system of the machine.

1.1.2 Application two-way version (Duo)

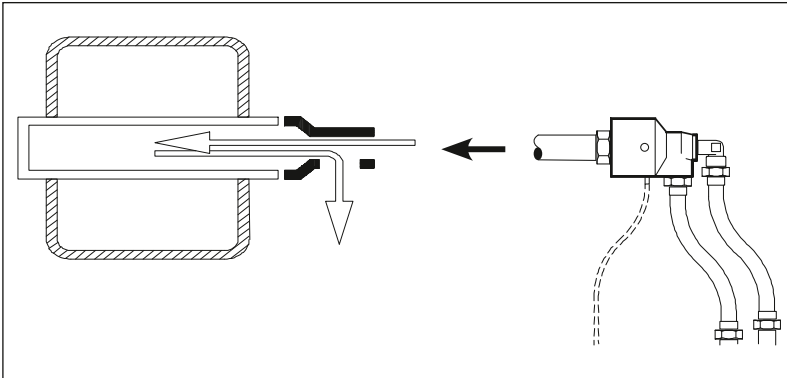

Fig. 3: Schematic diagram two-way version (Duo)

The rotating unions of the 54, 55 and 57 series are also available as two-way model (Duo).

The two-way rotating union is fitted with an axial connection at the elbow. Through this elbow the medium is conveyed into the machine shaft through a supply tube.

The return medium is absorbed by the same rotating union and conveyed into the piping system of the machine through the radial connection.

1.2 Misuse

This chapter provides information on known misuse of rotating unions of the 54, 55 and 57 series. The rotating unions are not suitable for the areas and applications described herein. Use in such areas or for such applications constitutes a misuse endangering people and machines and is therefore prohibited.

Prohibition for the following areas:

- Potentially explosive areas**
The rotating unions of the 54, 55 and 57 series shall not be used in potentially explosive areas, as they are not approved for the requirements in potentially explosive areas. Operation in such areas may cause explosions.
- Food**
Food, cleaning and disinfectant residues cannot be removed from the rotating unions. People may suffer poisoning.

Prohibition for the following applications:

- Conveying of combustible media or hydrocarbons**
Combustible media or hydrocarbons may ignite or cause explosions.
Exception: Thermal oil within the admissible temperature range. Please observe the safety data sheet of the used thermal oil.
- Connection to a piping system with excessive pressure**
If excessive pressure is applied to the rotating unions, supply pipes can come off and cause personal injury or property damage.
- Operation without lubrication**
Dry operation (without media) of the rotating union causes damage to the axial face seals.
- Connection to fixed pipes**
If connection is via fixed pipes, the rotating unions may leak and the ball bearings may get damaged.
- Conveying of media which are too hot**
If the media exceed the maximum admissible temperature for the rotating union, the static seals (elastomeric seals) can be damaged which may result in leaky rotating unions and personal injury or property damage.
- For series 55 only: Conveying continuous saturated steam**
Escaping steam may injure people seriously.
- For series 54 and 57 only: Conveying saturated steam**
Escaping steam may injure people seriously.

This list is not comprehensive and will be updated with results from product observation.

1.3 Safety Instructions

This chapter provides information on the hazards through rotating unions.

1.3.1 Hazards due to hot surfaces

The rotating unions are heated by the temperature of the media. Skin contact with heated rotating unions can cause injuries.

- Use safety gloves and PPE (Personal Protective Equipment) protecting against heat when handling the rotating union.
- Attach a clearly visible danger sign visibly on/next to the rotating union in order to warn of danger.

1.3.2 Hazards by improper hoses

For the connection of the rotating union to the machine, you have to choose appropriate hoses for the respective medium, which meet, the specifications for the application.

If you use incorrect hoses, they may become porous or burst. This can cause personal injury and/or property damage to components of the machine.

- In case of the media water, steam and thermal oil, use hoses which are suitable for the maximum system pressure of the machine and the maximum temperature of the media.

1.3.3 Hazards due to the media

When working on the rotating union, injuries can be caused by skin or eye contact with the media.

- Observe the safety instructions for the flow media. Observe the COSHH Safety Data Sheet for the flow media.

1.3.4 Hazards by faulty installation

If the rotating unions are installed incorrectly, hoses and connections may become leaky. The medium can escape. Depending on the medium, personal injury or property damage to the components of the machine may occur.

- Before installing the rotating union ensure that no feed pressure and no residual pressure is applied to the pipeline system of the machine.
- Install the rotating union on the machine using hoses only, in order to avoid stress on the rotating union.
- Install the hoses free from stress.
- Install the rotating union in a way that the leaking medium can be carried away securely downward at the lowest point and that the drain line shows a fall (min. 15°).
- Install the hoses to the rotating union prior to mounting it at the machine shaft.



1.4 Structure of Pictograms

This chapter provides information on the meaning of the pictograms used in the manual.



Warning

Warning

Potentially dangerous situation, which may result in death or serious injury.



Note

Note

Potentially harmful situation, in which the product or surrounding objects can be damaged.



Info

Application notes

and other useful information.

2 Information as to this Manual

The copyright as to this manual remains with *DEUBLIN*. Subject to changes!

- You can download the latest version of this manual under www.deublin.eu.
- Always use the latest version of the operating manual.

3 Information on the Name Plate

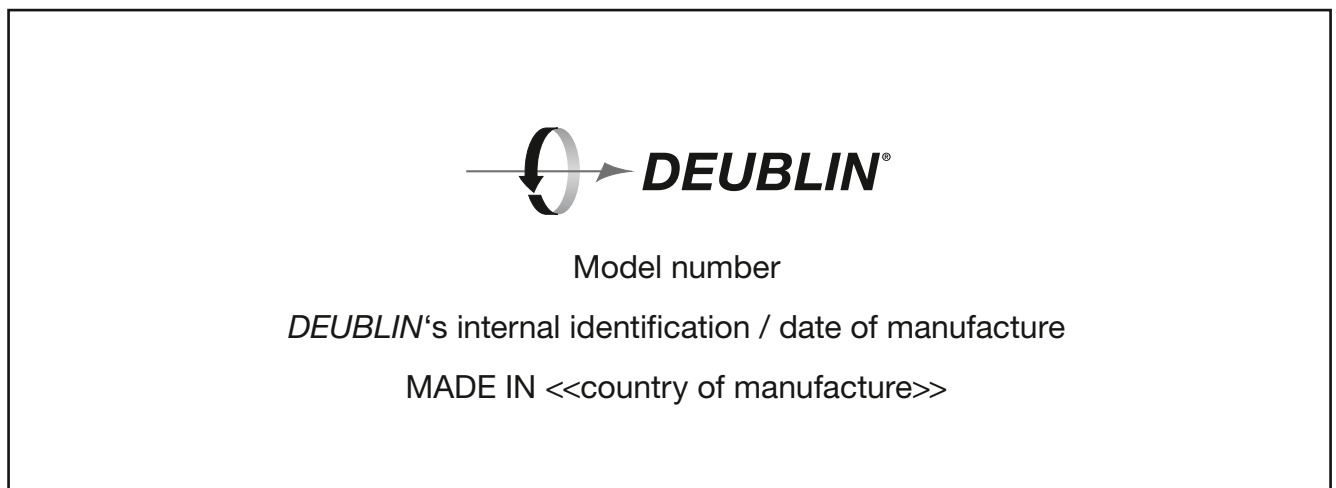

Fig. 4: Name plate

The coding of the model number is described in the catalogue. The model number corresponds to the order number.



4 Information on the Design

This chapter provides information as to which items have to be observed in the design in order to have a positive effect on the service life of the rotating union.



Info

You can obtain the drawings of the rotating unions from *DEUBLIN* in order to integrate the rotating union in your drawing.

4.1 Filtering of the Medium

Unfiltered media with a particle size of more than 60 µm result in increased wear of the rotating union.



Info

The larger the particles in the media, the higher the wear of the rotating union is. The higher the total of all particles (polluting load), the higher the wear is.

- Insert a filter in front of the rotating union which filters particles with a size of 60 µm and larger from the media.

4.2 Connecting Options of the Rotating Union at the Machine Shaft

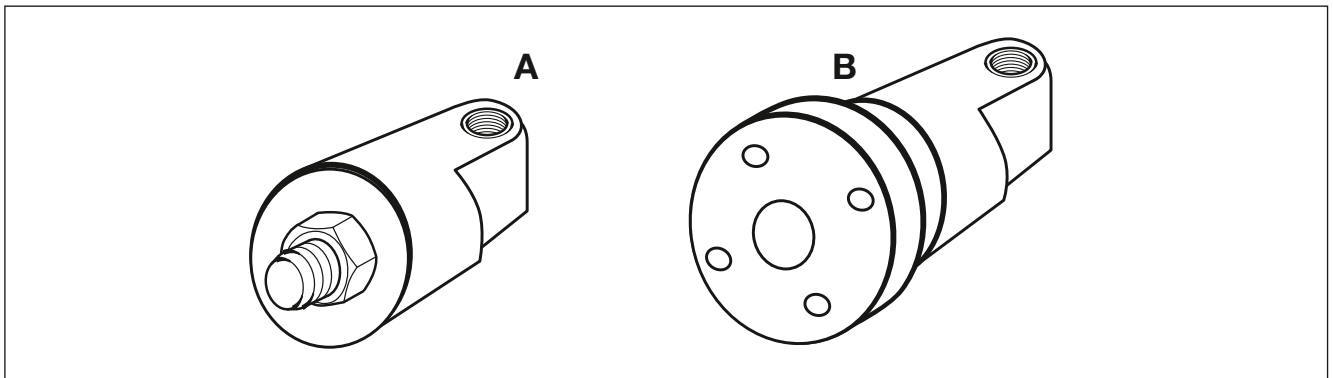

Fig. 5: Options for the installation on the machine shaft

The rotating unions can be fastened on the machine shaft by screwing (**A**) or by means of a flange (**B**) depending on the rotating union.

4.3 Options of Hose Installation

The following examples show how to install the hoses at the rotating unions.

These connecting options ensure that the hoses do not transfer stress to the rotating unions when the machine shaft moves.

- Please pay attention to the chapter “1.3 Safety Instructions” regarding the design.

4.3.1 Connection of hose to the rotating union

The hoses must be installed without stress and bends so that they do not apply any forces to the rotating union. The following figures show examples of installation.



Fig. 6: Connect hoses horizontally

If the rotating unions are installed with connections positioned horizontally, connect the hoses as shown.



Fig. 7: Hoses bent by 90°

If the hoses are to be guided away from the rotating unions vertically and bent by 90°, connect the hoses as shown.

4.3.2 Hose connection in case of additional axial movement of the machine shaft

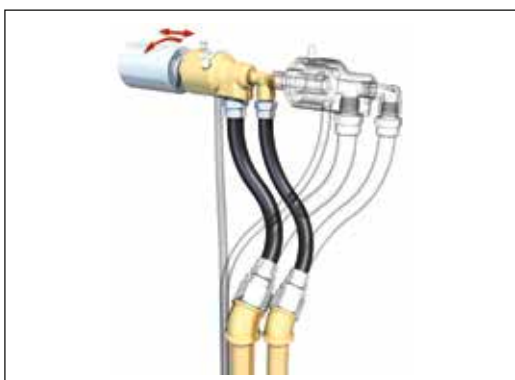

Fig. 8: Hoses laid in a curve

If the rotating unions are installed to machine shafts with an oscillating (axial) movement, the hoses must be stress-free in both extreme positions.

4.3.3 Hose connection for hoses with SAE flange



Info

Only possible, if the rotating union is ordered with SAE connections.



Fig. 9: Flange connection

The hoses are fastened at the rotating union by means of its SAE flanges using four screws.

4.3.4 Optional: Connection of a leakage line



Info

Only possible, if the rotating union is externally mounted.

In order to prevent surrounding components from being damaged by escaping medium, you can connect a leakage line to the rotating union, if required.

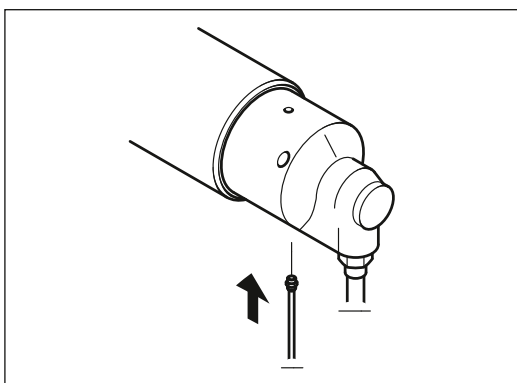

Fig. 10: Schedule connection of leakage line

The rotating unions are equipped with leakage holes.

- When used in dirty environment, we recommend to protect the leakage holes against penetrating dirt. You can order sealing plugs at *DEUBLIN*. If you close the leakage holes, you have to provide the rotating union with ventilation, if applicable by means of a second leakage connection. Without ventilation the leaking medium cannot drain off.
- Position the rotating union in a way that you can always connect the leakage line in 6 o'clock position (at the lowest point) to a leakage hole.

5 Installation

The union installation is described in an additional manual which is supplied with each rotating union. Please follow the additional instruction "Installation" for a secure and correct installation of the rotating union. The instruction "Installation" is available online under www.deublin.eu.

- Ensure that the person installing the rotating union receives the following information:
 - Position and location of the rotating union in the machine
 - Plan for connection of hoses
 - Position of leakage line
 - Information on the media

6 Information on the Operation



Note

Damage to components due to missing lubrication (Dry run)

The axial face seals of the rotating unions are lubricated by the medium. If the rotating unions are operated without medium present they are not lubricated and will thus be damaged.

- Ensure that the rotating unions are operated with a medium.
- Switch off the plant/machine, if the rotating unions are operated without medium.

7 Storage



Note

Damage of component due to incorrect storage

If you store the rotating unions incorrectly, they become leaky or get damaged.

- Store the rotating unions in a dry space between 3 °C and 40 °C.
- Store rotating unions for two years at the most.

8 Maintenance

This chapter provides information on how to extend the service life of the rotating unions by means of maintenance.

8.1 Maintenance Intervals

You can avoid early wear of the rotating unions, if you adhere to the maintenance intervals described herein.



Warning

Risk of injury due to hot or cold surfaces

The rotating unions are heated or cooled by the temperature of the medium. Skin contact with these heated or cooled rotating unions can cause severe injuries.

- Before starting to work on the rotating union, allow the machine to cool down.
- Use safety gloves and PPE (Personal Protective Equipment) protecting against heat or cold depending on the application of the rotating unions.



8.2 Daily Inspection

Check the rotating unions for tightness.



Risk of injuries due to applied line pressure

If you have to work on the rotating union and feed pressure of the medium is applied or there is residual pressure in the piping system of the machine, the medium can escape under pressure when releasing the connections. You and other people may suffer severe injuries.

- Ensure that no feed pressure is applied.
- Ensure that there is no residual pressure in the piping system.

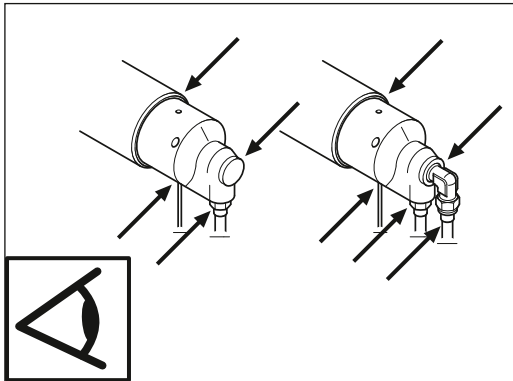

Fig. 11: Inspect visually

During operation of the machine, leakages may occur at the connections and hoses depending on the requirements to the rotating unions.

1. Carry out daily visual inspections in order to check whether leakages occurred at the connections (see arrows).

If you detect leakage:

1. Stop the machine.
2. Replace the defective hoses with new ones.
3. Seal leaking connections.
4. If the rotating union is worn and leaks, replace it with a new one. Repair kits for various models can be obtained from *DEUBLIN*.

8.3 Maintenance after Operating Hours

This chapter describes how to relubricate the rotating unions.



The maintenance operations described below have to be executed in case of series 55 and 55 Hot Package only. Rotating unions of the series 54 and 57 are lubricated in the factory for the entire service life.

- The rotating unions are already lubricated in the factory and delivered ready-to-be-installed.



The indicated volumes of grease and intervals for relubrication are based on experience resulting from the information of the manufacturer of the lubricant and the operating parameters of the rotating unions. The information given herein refers to operating hours depending on the respective speed.

- In case of doubt, consult *DEUBLIN*.

Lubricate the ball bearings of the rotating unions at the stated lubricating intervals using the listed volume of grease suitable for the operating conditions. If you do not adhere to these instructions, the service life of the ball bearings is reduced.

8.3.1 Allowed lubricants

Series	allowed lubricants
54 / 55 / 57	TEXACO CHEVRON SRI 2 GREASE NLGI 2

Series	allowed lubricants
55 Hot Package	DUPONT KRYTOX XHTRUF KLÜBER BARRIERTA L55/0, L55/2 LUBCON TURMOTEMP II/400

8.3.2 Volume of grease for lubrication



Note

Damage to the component due to excessive grease

If you put too much grease in the ball bearings, the latter can be damaged.

- Adhere to the stated volumes of grease for lubrication.



Note

Damage of part by loss of grease quality

If e.g. the grease for relubrication is supplied by a central lubrication system to the rotating unions, the grease may lose its essential characteristics. The bearings of the rotating unions will be damaged.

- Make sure only fresh new grease is fed to the bearings.
- Comply with the specifications for service life of the grease manufacturer.

Series	Model	Volume of grease (g)
55	55	3.5
	155	5.5
	255	10
	355	10
	525	12
	555	18
	655	18
	755	42
57	857	42

Series	Model	Volume of grease (g)
55 Hot Package	55	7
	155	12
	255	19
	355	24
	525	29
	555	40
	655	47

8.3.3 Relubrication intervals for series 55 and models 857

The intervals for relubrication depend on the operating conditions of the rotating unions.



Relubrication intervals for light duty operating conditions

Light duty operating conditions are:

- Medium with a temperature of max. 75 °C
- Few vibrations
- Little humidity
- Hardly polluted environment

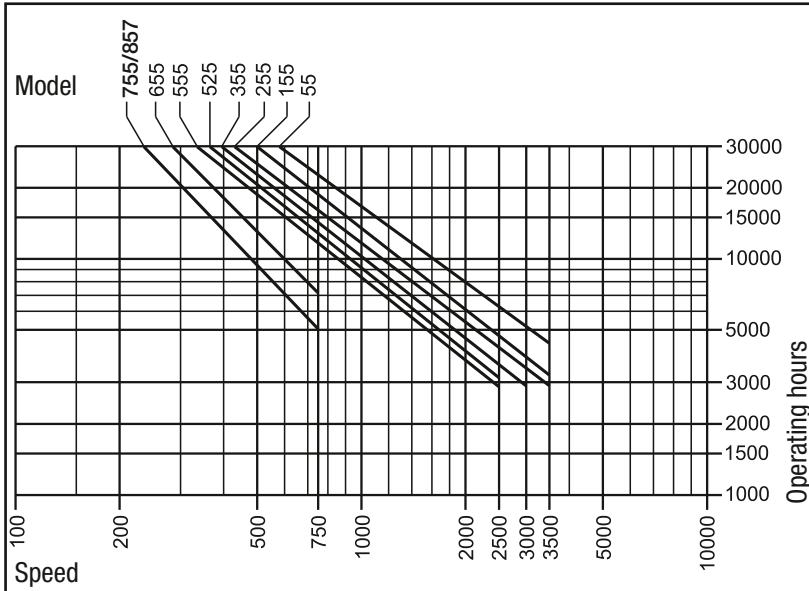

Relubrication intervals for medium-heavy duty operating conditions

Medium-heavy duty operating conditions are:

- Medium with a temperature of 75 ° to 120 °C
- many vibrations
- much humidity
- extremely polluted environment

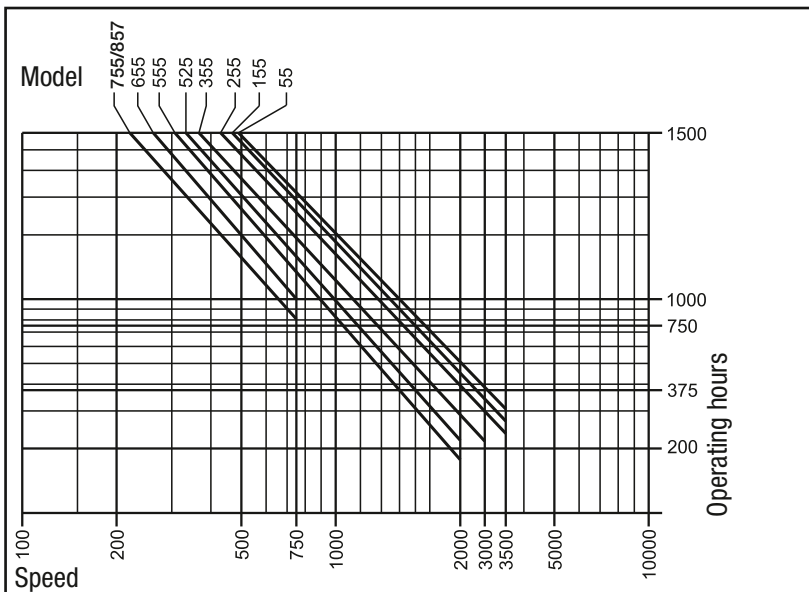

Relubrication intervals for extreme operating conditions

If the operating conditions exceed the easy and medium-heavy operating conditions, the lubrication interval, volume of grease and grease type have to be adapted to the application.

- Please consult your lubricant supplier.

8.3.4 Relubrication intervals for 55 Hot Package series

Lubrication interval after commissioning

Lubricate the rotating union with the stated volume of grease and grease type after 1,000 operating hours for the first time.

Subsequent lubrication interval



Info

If you convey media with a temperature **below** 100 °C through the rotating union, you do not have to relubricate the rotating union.

Operating Conditions	Subsequent lubrication intervals
from 100° to 150 °C	after 6,000 operating hours
from 150° to 160 °C	after 3,000 operating hours

8.3.5 Lubricate the rotating union

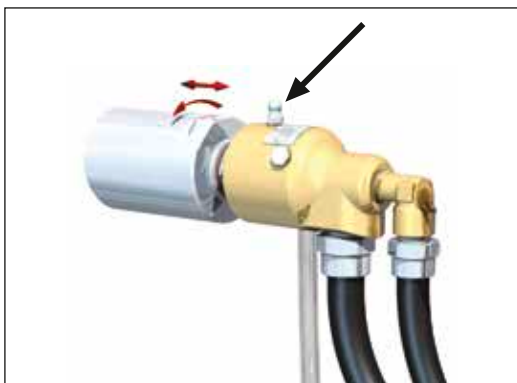

Fig. 12: Attach grease gun for relubrication

The following paragraphs describe how to place the grease gun and inject the stated volume of grease into the ball bearing.

1. Attach the grease gun to the lubricating nipple (see arrow).
2. Ensure that the connector of the grease gun is placed correctly on the lubricating nipple.
3. Actuate the grease gun in order to inject the stated volume of grease into the ball bearing.
4. Count the operating hours for the following lubrication interval.

9 Trouble Shooting

This chapter provides the following information:

1. Which problem may occur?
2. What can be the cause of the problem?
3. How can you eliminate this problem?

9.1 Potential Causes for Errors and their Elimination



Warning

Risk of injuries due to applied line pressure

If you have to work on the rotating union and feed pressure of the medium is applied or there is residual pressure in the piping system of the machine, the medium can escape under pressure when releasing the connections. You and other people may suffer serious injuries.

- Ensure that no feed pressure is applied.
- Ensure that there is no residual pressure in the piping system.

Error	Potential causes	Elimination
Rotating union is leaky after installation	Incorrect installation	<ol style="list-style-type: none"> 1. Stop the machine. 2. Ensure that the connections are sealed according to the manual "Installation". 3. Ensure that all hoses are installed without stress. 4. Ensure that all seal faces are clean.
	Seal faces of the rotating union are damaged	<ol style="list-style-type: none"> 1. Pack rotating union. 2. Send rotating union to <i>DEUBLIN</i> for overhaul/service.
	Rotating union is defective	
Rotating union leaks before the end of the expected service life	Medium is contaminated	<ol style="list-style-type: none"> 1. Stop the machine. 2. Drain medium. 3. Send rotating union to <i>DEUBLIN</i> for overhaul/service, if required. 4. Mount new filter. 5. Flush the piping system of the machine. 6. Fill in new medium.
	Rotating union is not designed for the respective application	<ol style="list-style-type: none"> 1. Ensure that the correct <i>DEUBLIN</i> Rotating Union is used. 2. Contact <i>DEUBLIN</i> if required.
Rotating union runs untrue or wobbles	Thread and/or concentricity outside the admissible tolerance.	<ol style="list-style-type: none"> 1. Stop the machine. 2. Remove rotating union. 3. Manufacture new thread or flange. 4. Install rotating union.
	Rotating union is mounted incorrectly.	

9.2 Pack Rotating Union for Transport

The rotating union has to be protected against mechanical impact and humidity during transport to ensure that the rotating union will arrive at *DEUBLIN* without being damaged.

1. Dismount the rotating union in reverse order of the installation (see Installation).
2. Ensure that the rotating union is free from the respective media.
3. Use a cardboard box which is suitable for the weight of the rotating union.
4. Cushion the base of the cardboard box with a soft material, e.g. air bubble film.
5. Wrap the rotating union with a soft material, e.g. air bubble film.
6. Ensure that no packing material or dirt can penetrate the opening of the rotating union.
7. Position the rotating union in the middle of the cardboard box.
8. Fill the free space around the rotating union with newspaper or another suitable material.
9. Close the cardboard box by means of tape.

10 Disposal

10.1 Dispose of Packaging

- Dispose of the packaging (cardboard box and plastics) according to the national standards, regulations and directives.

10.2 Dispose of Rotating Union

Mainly, the rotating unions consist of metals, which can be reused within the reclamation of scrap. Decontaminate unions / parts and dispose of in an “Environmentally Friendly” way.

- Dismount the rotating union in reverse order to the installation (see Installation).
- Flush the rotating union.
- Collect the dirty flushing media.
- Dispose of the collected flushing media according to the national standards, regulations and directives.
- If you use thermal oil, please observe the instructions of the thermal oil manufacturer.
- Dispose of the rotating union according to the national standards, regulations and directives.

In case of repair, *DEUBLIN* disposes of all used parts.

11 Spare Parts

The rotating unions have a limited service life and include wearing parts. Wearing parts are excluded from the warranty. All static and dynamic sealing elements of a component are considered wearing parts, as well as ball bearings.

Repair kits are available for several models of the rotating unions and can be obtained from *DEUBLIN*. Please ask your *DEUBLIN* Service.

You need special tools and repair instructions for repair of the rotating unions which can be obtained from *DEUBLIN* as well.



Info

Note

If you do not want to repair your rotating union on your own, *DEUBLIN* will be pleased to help you. If requested, *DEUBLIN* will exchange all wearing parts and clean all components of the rotating union. Before repaired rotating unions leave the premises, they will be subjected to an operational check. The repaired rotating union is returned with a standard “*DEUBLIN* Warranty” valid for 12 months.

Reliability

Many years' experience, ongoing liaison with customers, innovations sourced inhouse and from suppliers place *DEUBLIN* in a position providing reliable Rotating Unions at the highest level.

When it comes to concrete applications, maximum service life is guaranteed by matching the sealing to the respective medium.

The service life is also equally maximized by maintaining cleanliness when storing and handling the Rotating Union and by adhering to the guidelines issued by *DEUBLIN* in respect of the conditions on the customer's premises.